

## OFFICIAL GRAND PRIX PINWOOD DERBY® KIT

*Please read these Rules and Instructions before building your car.*

The Pinewood Derby® is open to all Cub Scouts. Cars should be built by the Cub Scouts with some adult guidance. Any technical assistance should be fully explained to the Cub Scout so that he can use that knowledge on future projects. Because it is difficult to establish how much help was given in building the car, some Packs have a separate Pinewood Derby Race for adults.

**IMPORTANT:** The Race Committee should decide on rules and race procedures, then have them printed and distributed to all participants at least two weeks before the race.

### CAR SPECIFICATIONS:

- Width - 2 3/4" • Length - 7" • Weight - Not over 5 Ounces
- Width between wheels - 1 3/4"
- Bottom clearance between car and track - 3/8"

### RULES

Wheel bearings, washers and bushings are prohibited. The car shall not ride on springs. Only official Cub Scout Grand Prix Pinewood Derby wheels and axles are permitted. Only dry lubricant is permitted. Details, such as steering wheel and driver are permissible as long as these details do not exceed the maximum length, width and weight specifications. The car must be free-wheeling, with no starting devices. Each car must pass inspection by the official inspection Committee before it may compete. If, at registration, a car does not pass inspection, the owner will be informed of the reason for failure, and will be given time within the official weigh-in time period to make the adjustment. After final approval, cars will not be reinspected unless the car is damaged in handling or in a race.

### BUILDING INSTRUCTIONS

Check the grooves to ensure that each is at a perfect 90-degree angle to the car body. A car with untrue axles tends to steer to one side or the other, causing it to rub up against the side of the lane strip, slowing it down. You can check the groove angles by using a square, a protractor, or even a piece of paper.

Lay square on block to check for squareness and alignment of slot.

Use two hacksaw blades side by side to redress the slots. Use the edge of the square as a guide.

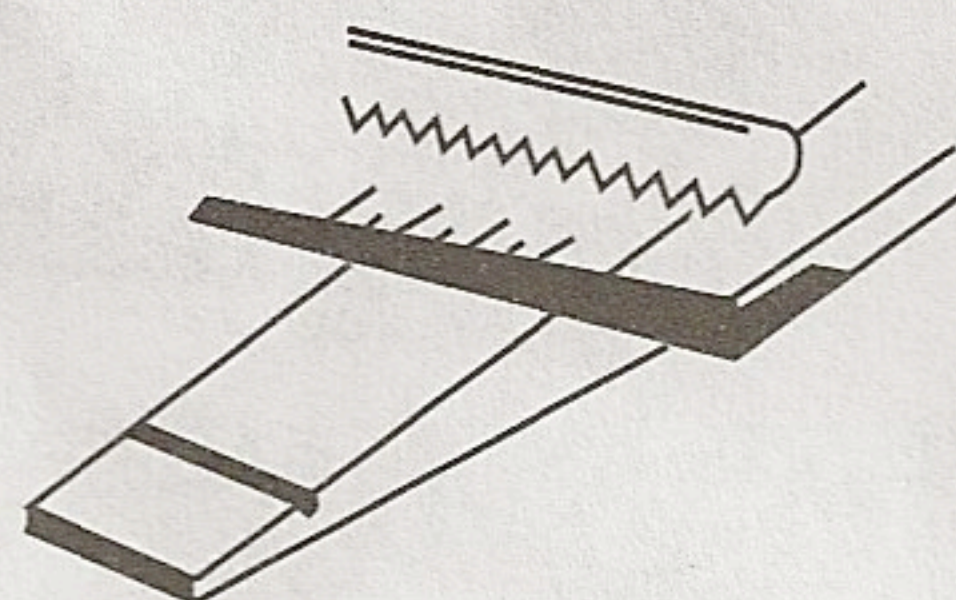
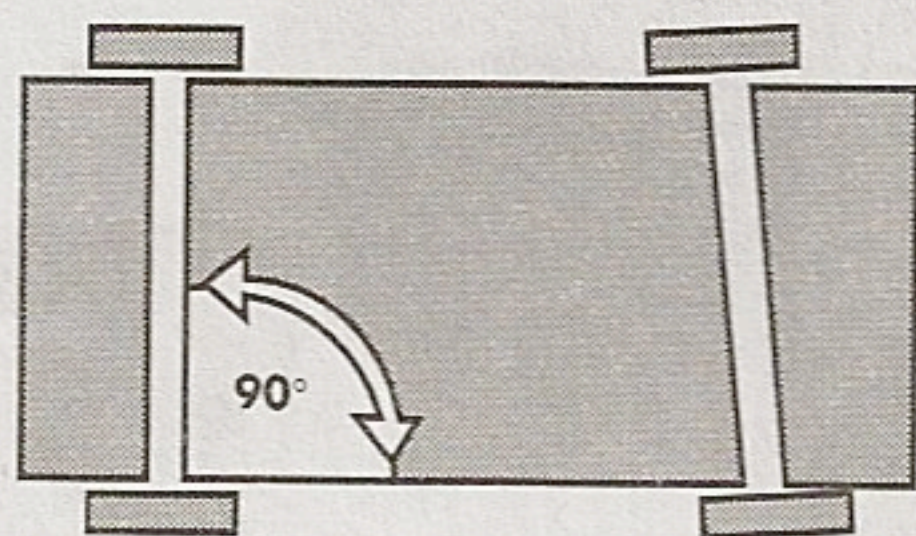

Choose your favorite design, then mark the block accordingly (See Figure 1). Lay car body on the side, then gently drive the axles into the grooves within 1/4" of the axle head. Axles should fit tight. With a pair of pliers, remove axles by pulling and turning gradually (See Figure 2). Repeat on the other side of block. Most of the cutting can be done with a hand saw, then finished with sandpaper (See Figure 3). Details such as fins and scoops should be added now. Any additional weight needed to achieve a total of 5 ounces should be built into the car.

**NOTE:** If the car design you chose has a narrow body, make sure the area where the axles are inserted into the body remains 1 3/4" wide, or wheels will not fit over the guide strips of the track.

### PAINTING AND WHEEL ASSEMBLY

Apply several coats of sanding sealer; then sand entire car with a fine-grade sandpaper. Give model at least two coats of fast-drying paint in your choice of color. When paint is completely dry sand with a fine sandpaper, apply a final coat of paint and allow to dry thoroughly. TO FINISH, rub entire car with a rubbing compound. Details such as steering wheel, windshield, driver, racing numbers, etc., should be added now. For a super finish apply a coat of auto wax and rub to a high gloss. Pre-lubricate axles and wheels using dry powdered lubricant. Do not use regular oil or silicone spray, since it may soften the plastic. Slide wheels over axles, then gently tap them into the car body grooves with a 1/4" dowel or similar object to within 1/32" of car body. (See Figure 4). Make sure wheels turn freely.

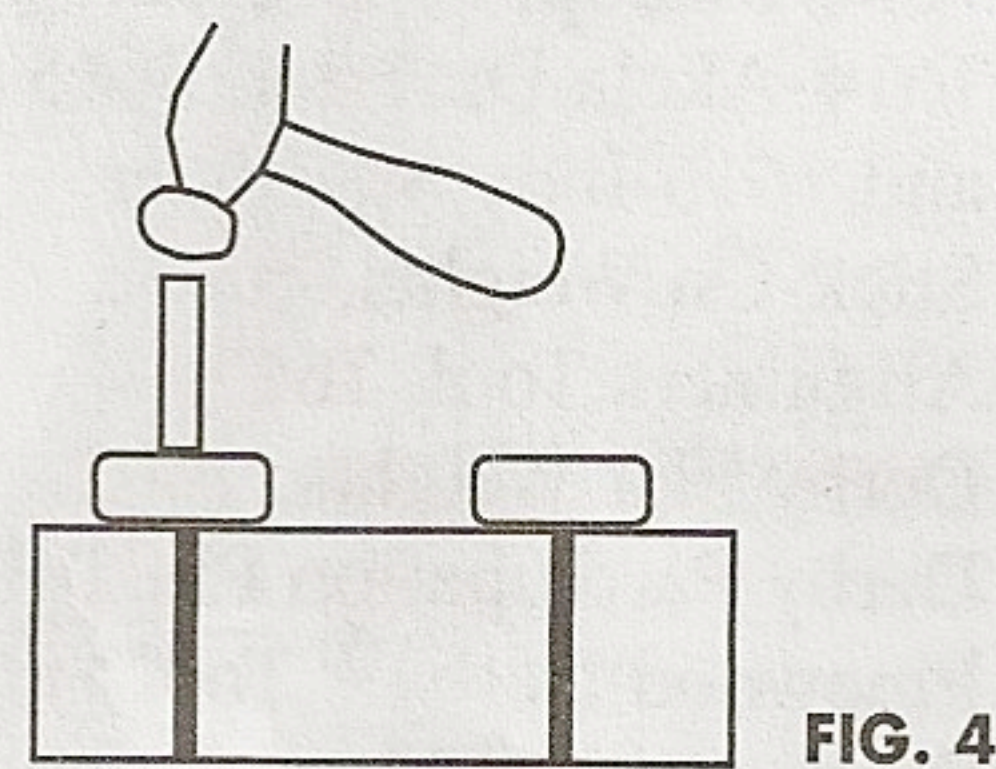
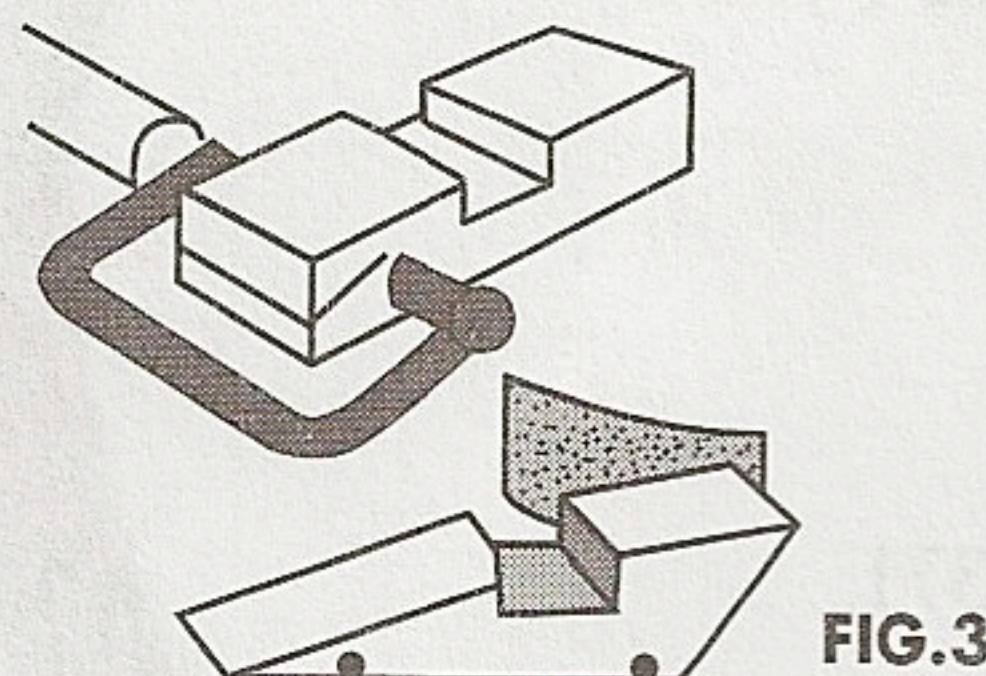
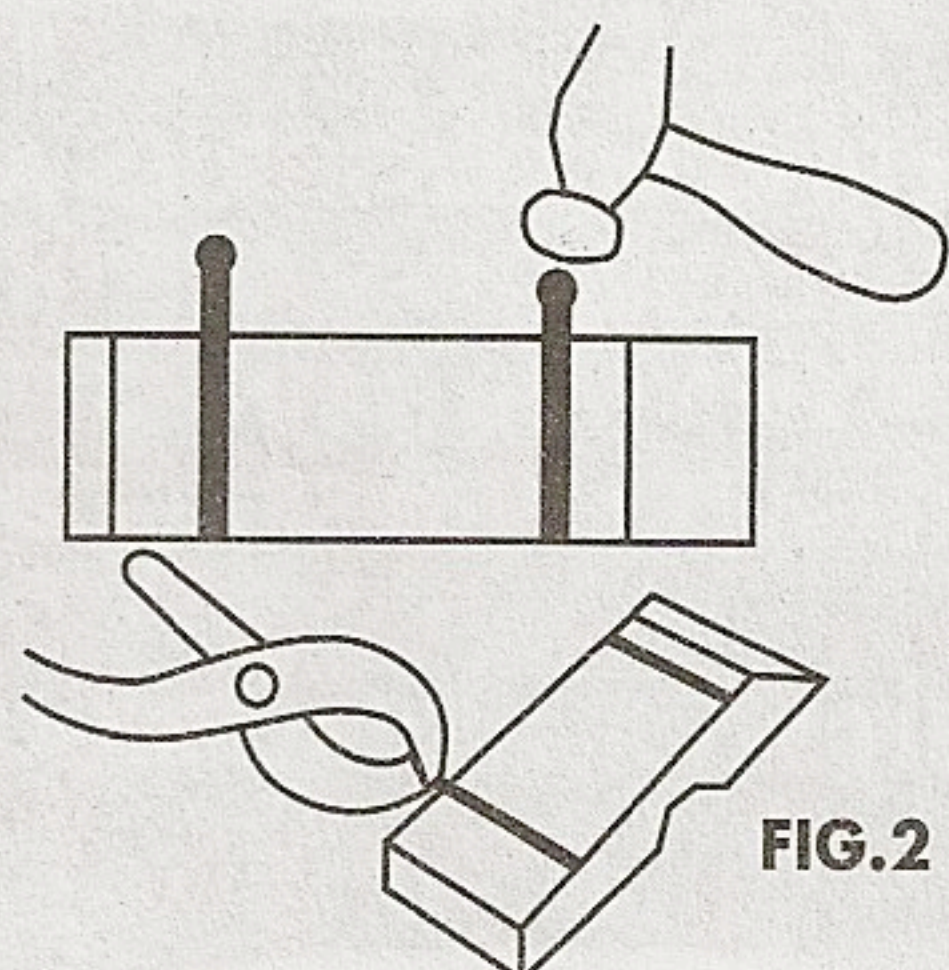
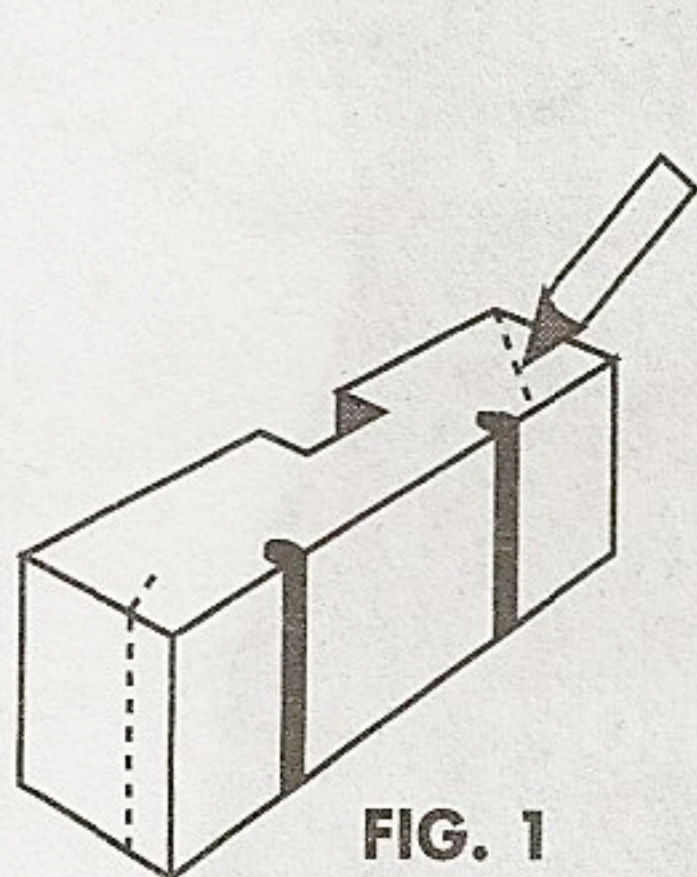

Due to many requests we have eliminated the cockpit section in the Pinewood Derby block to allow for more designs.